



# **AEROEX Technologies Inc.**

## **Oil Mist Eliminator**

Model ROX-2000



## **Installation & Service Manual**

[www.aeroex.ca](http://www.aeroex.ca)

AEROEX Technologies Inc.  
90 Ellis Dr.  
Barrie, ON Canada, L4N 8Z3  
Tel: 705-734-0549 Fax 705-734-1013

Sales  
905-655-7295  
sales@aeroex.ca



## Model ROX Series Specifications

### AEROEX – Mist Eliminator

For highly effective separation of oils, emulsion, water. Designed to exhaust air from metalworking machinery and oil reservoirs. Aerosol measurements less than 0.020 mg/m<sup>3</sup> at 0.3 microns.

#### Consisting of:

- Powdered coated mild steel housing.
- Motor and fan impeller
- First stage mechanical separator elements.
- Second stage filtration by droplet agglomerator. (Depth Fiber Filter)
- 3<sup>rd</sup> stage polishing filter 95% @ 0.3 microns.
- Optional On-Line Cleaning System.

#### Specifications:

Model	CFM (m <sup>3</sup> /hr)	Sound dB(A)	Machine Tool Enclosure Volume ft <sup>3</sup>	Motor hp	Voltage RPM	Amps	RPM
ROX-2000	1700 – 2250 (2900 - 3800)	79	350 - 750	3.0	230/460 575/3/60	7.34/3.67 2.94	3450

Model	Dimensions	Weight	Duct Con.
ROX-2000	58" x 26" x 52"ht (1473 x 660 x 1320 mm)	450 lb (205 kg)	10" (254 mm)

#### Decription

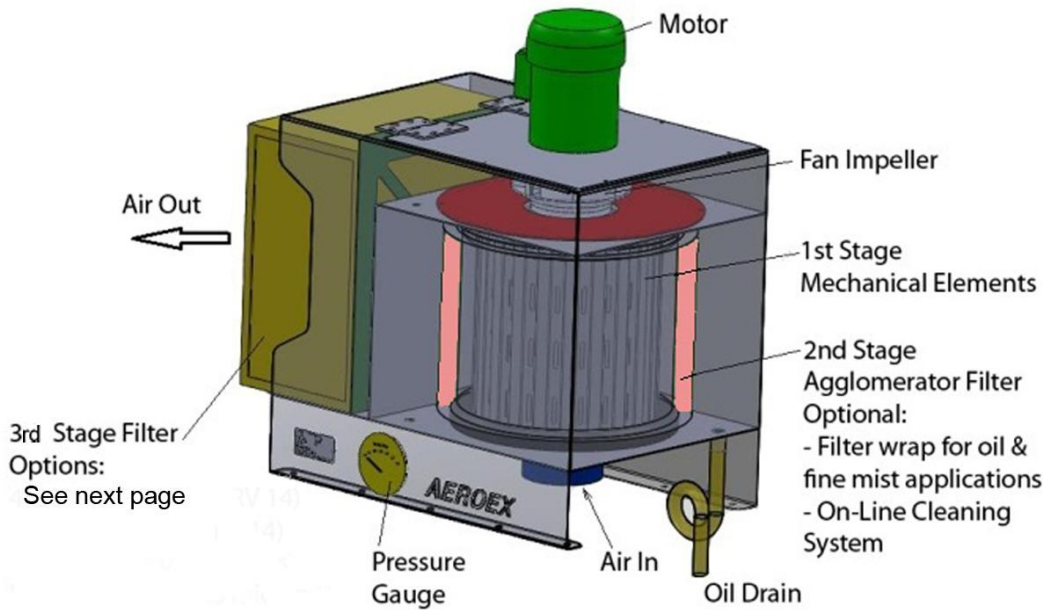



## Installation:

- Mount mist collector level.
- Units can be mounted directly on top of machines, on a post or on the wall.
- Ensure that there is 36" free space above to open lid and remove filters.
- Minimize the length of ducting to avoid air flow losses.
- Metal ducting or flexible hose can be used.
- Do not locate suction intake on machining applications in direct line of the cutting spray.
- A chip strainer mounted in the machine (CNC) enclosure is recommended.
- Connect the 2 oil drain lines using a pee trap (5") or loop in hose.
- Connect into 1 hose after pee trap.
- Install motor starter and set overloads.
- Connect electrical power to motor using a flexible cable.
- Check motor rotation.

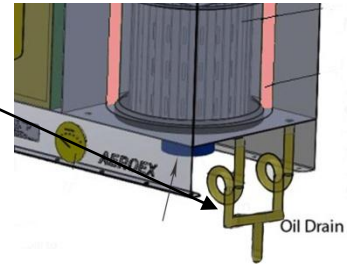

## Typical installation:

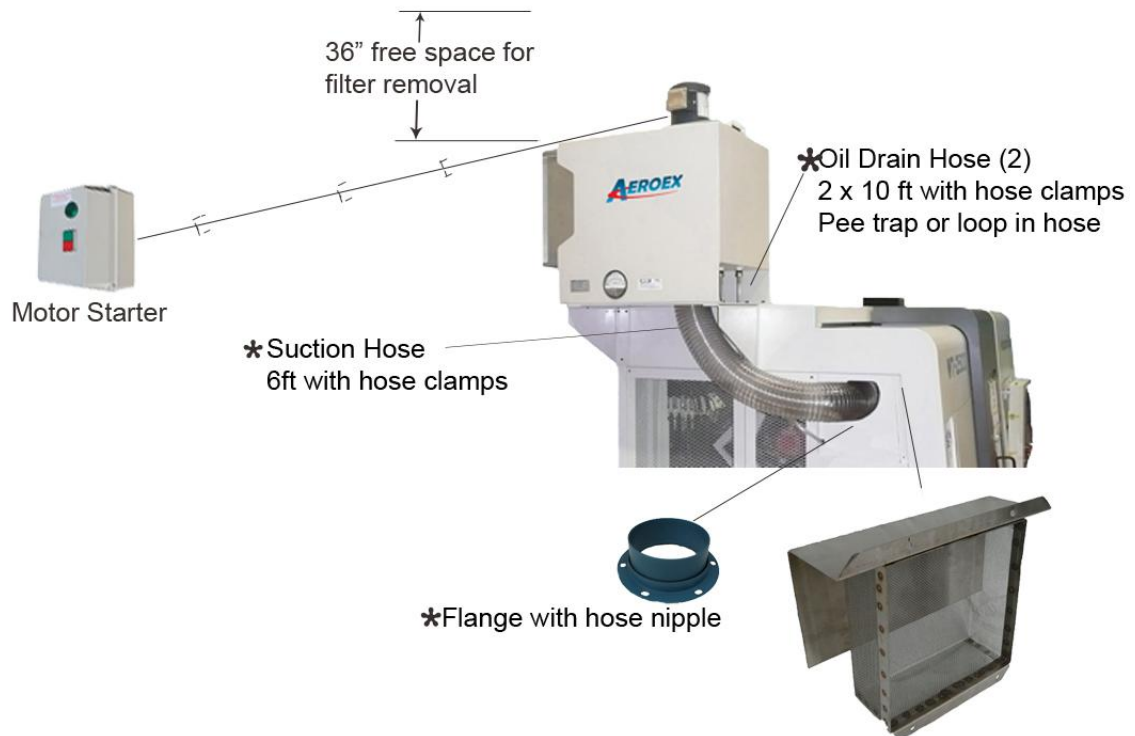

### Installation Options:

- \*Installation kit
- Motor starter control panel.
- Floor mount stand
- Wall mount stand

- \*Chip Strainer with baffle deflector  
Mount in machine tool enclosure  
12" x 10" x 5"



## Maintenance:

The mist collector can operate for long periods without maintenance. The maintenance period will depend on the type of oil & solids/chips in air stream. Some soluble oil & synthetic concentrates will congeal requiring the mechanical separator elements and agglomerator filter media to be manually cleaned/washed. The air flow will reduce if this happens.

Inspect the unit after 3 months, 6 months & 1 year to establish the maintenance interval. If there is no fouling, the mist separator can run indefinitely without maintenance. It is recommended that the 2<sup>nd</sup> stage agglomerator filter media be replaced every 10 years.

### Optional On-Line Cleaning System:

Eliminates manual cleaning of 2<sup>nd</sup> stage media.  
For coolant applications only.  
Connect to water or clean coolant.  
Turn fan motor off.  
Flush for 5-15 min every 2– 4 months.

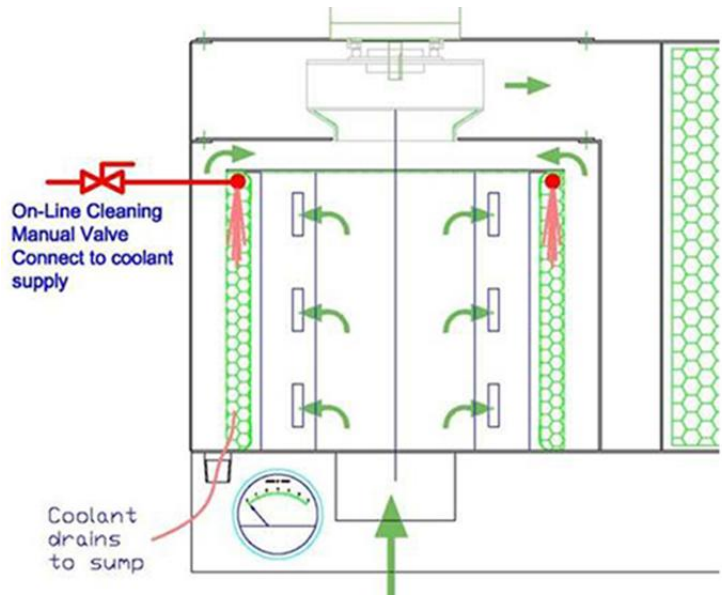



HEPA filter replacement:  
Replace when magnehelic pressure gauge reaches 3" wg.





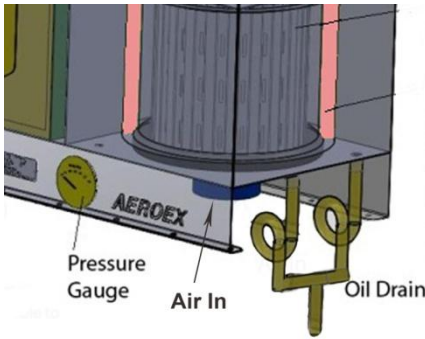



## Disassembly:

<p>Disconnect and lock-out electrical power.</p> <p>Remove bolts (4) on hinged lid.</p> <p>Remove the bolts(4) on impeller inlet plate.</p>		
<p>Remove impeller inlet plate.</p> <p>Remove nut (1) on pressure plate and lift out plate.</p>		
<p>Remove 1<sup>st</sup> stage mechanical separation elements. They can be disassembled for cleaning by removal of the bolts (6).</p> <p>Remove 2<sup>nd</sup> stage filter media (agglomerator). This is a permanent media and can be washed many times.</p>		





<p>Replace bottom foam gasket each time HEPA filter is changed.</p>		
<p>Check oil drain line, clean if necessary.</p>		
<p>To remove 3<sup>rd</sup> stage filter (HEPA), loosen straps.</p>		

## Filter Options:

Filter Options	Part Number		Application/Comments
1 <sup>st</sup> stage Mechanical Elements	2000ME-002		Standard on all units Does not normally need replaced.
2 <sup>nd</sup> stage Agglomerator filter	2000AF-001		Coolant & oil Standard on all units
2 <sup>nd</sup> stage Agglomerator filter with single filter wrap	2000FW-001		High coolant mist, cast iron, oil Will reduce air flow 100 cfm
2 <sup>nd</sup> stage Agglomerator filter with double filter wrap.	2000FW-002		High oil mist Will reduce air flow 200 cfm.
3 <sup>rd</sup> stage filter One 4" MERV 14 24" x 24" x 4"	2000PF-002		For fine mist to protect HEPA. Suggest using 2 <sup>nd</sup> stage filter wraps.
3 <sup>rd</sup> stage filter HEPA 95% @ 0.3 microns 24" x 24" x 12"	2000HF-002		Captures 100% of mist Captures 80%- 99% smoke
3 <sup>rd</sup> stage filter HEPA 99.97% @ 0.3 microns 24" x 24" x 12"	2000HF-001		Captures 100% of mist Captures 99.9% smoke

## 2<sup>nd</sup> Stage Filter Wrap Instructions

### For oil and other fine mist applications

<p>1 st stage mechanical element must have 3 elements. Remove outer element if there is 4. Replace existing bolts (6) with 1.5" long bolts.</p>	
<p>Lay wrap on floor or table and roll tightly onto filter. Start at opposite end to the draw string. Approximately 2" will extend on both ends.</p>	
<p>The wrap draw string end must be last to be rolled onto filter.</p>	
<p>Tie draw string at both ends. A foam rubber spacer under mechanical elements could be required to even height between filter and mechanical elements.</p>	

**Notes:**

Air flow will be reduced 100 - 200 cfm  
 Single wrap for fine coolant mist, cast iron etc.  
 Double wrap for straight oil applications.

Parts List Model ROX-2000

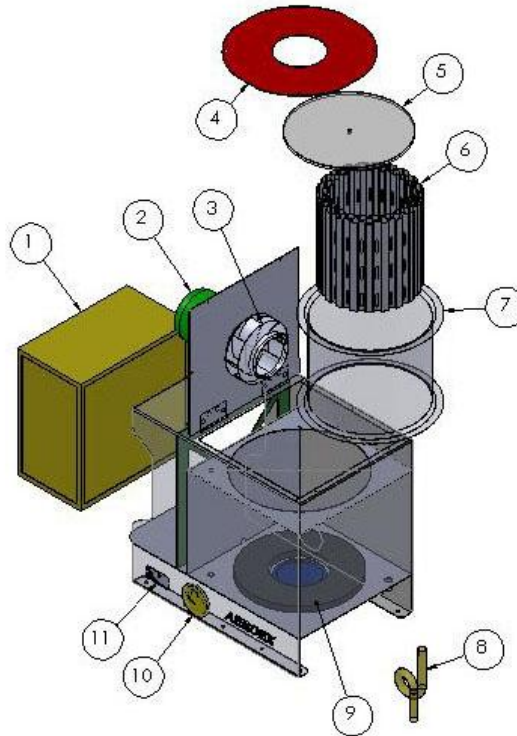

Item #	Description	Qty	Part #
1(a)	HEPA filter, 12" 95% @ 0.3 um	2	2000HF-002
1(b)	Pre-filter 4" (optional)	2	2000PF-002
2(a)	Motor 3hp 230/460/3/60	1	2000M-230460
2(b)	575/3/60	1	2000M-575
3	Fan impeller, TEK 310	1	2200FI-001
4	Impeller inlet plate	1	2200FI-001
5(a)	Pressure plate & gasket	1	2000PP-001
5(b)	Pressure plate gasket	1	2000PPG-001
6	1 <sup>st</sup> stage mechanical elements	1	2000ME-001
7(a)	2 <sup>nd</sup> stage agglomerator filter	1	2000AF-001
7(b)	2 <sup>nd</sup> stage filter wrap, single	1	2000FW-001
7(c)	2 <sup>nd</sup> stage filter wrap double	1	2000FW-002
8	Drain hose, 2 drains	per foot	2000DH-001
9	Bottom foam gasket	1	2000BG-001
10	Magnehelic pressure gauge	1	2000MG-001
11	Nameplate	1	n/a
<b>Accessories</b>			
12	Installation kit	1	2000IK-001
13	Suction hose, 10"	per foot	2000SH-010
14	Flange with hose nipple, 10"	1	2000HN-010
15	Hose clamps. 10"	2	2000HC-010
16	Suction strainer	1	2000SS-001

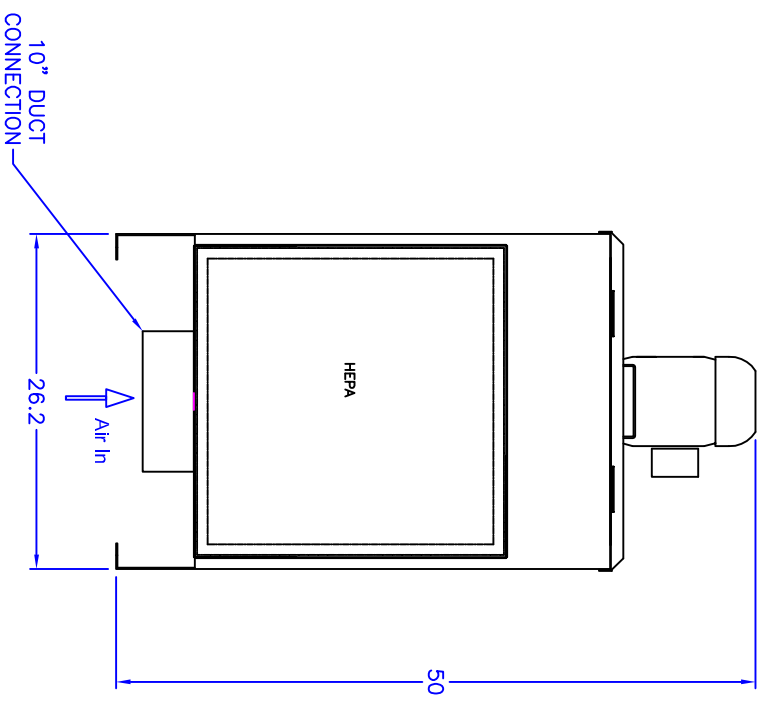
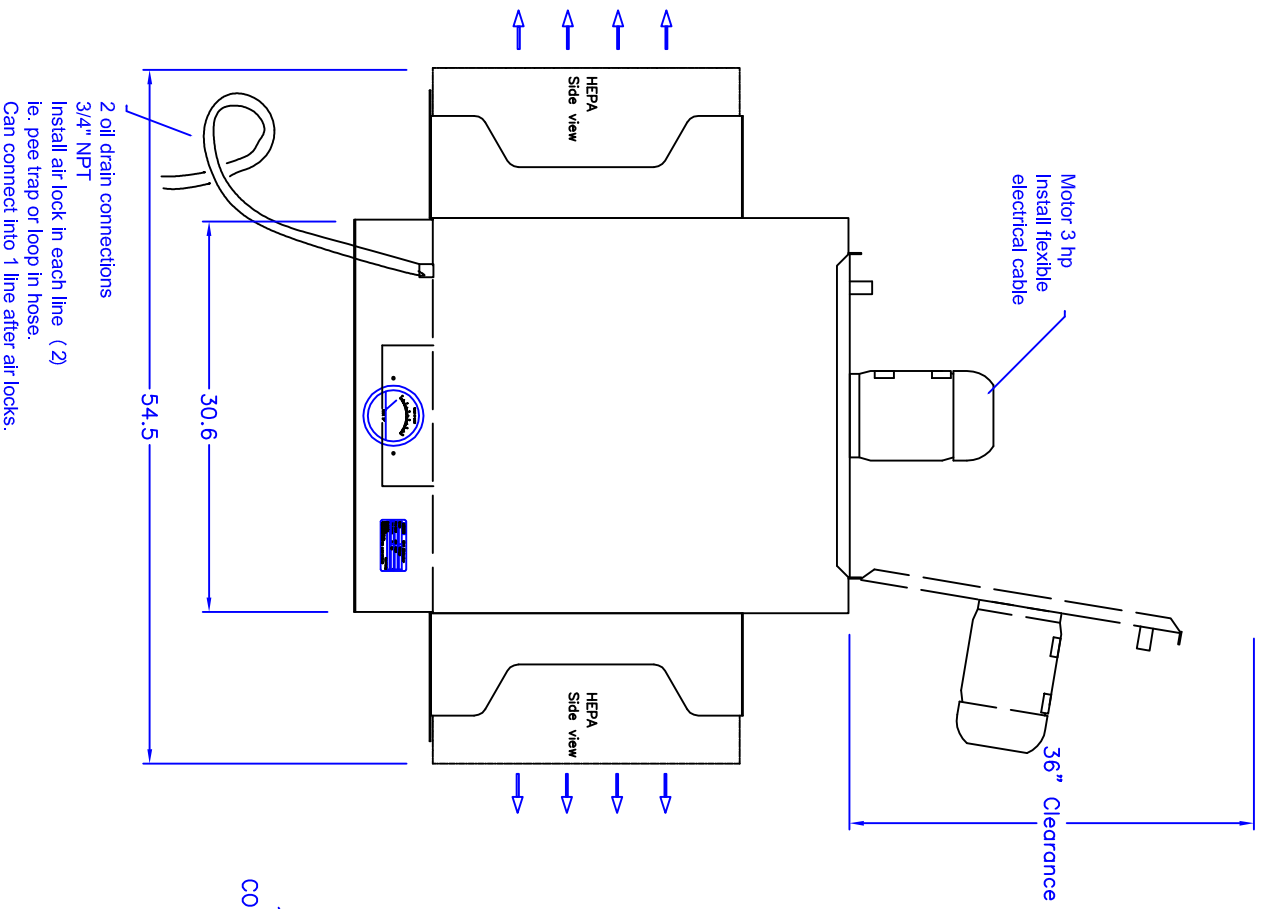

**AEROEX Technologies Inc.**

90 Ellis Drive  
Barrin, Ontario L4M 5S3  
Tel: (705) 794-0100 Fax: (705) 794-1013

DESCRIPTION:

ROX-2000 Dimension Drawing

DATE: Jan. 26/11 DESIGNER: T.B. SCALE: DWG NO: B-20-0001

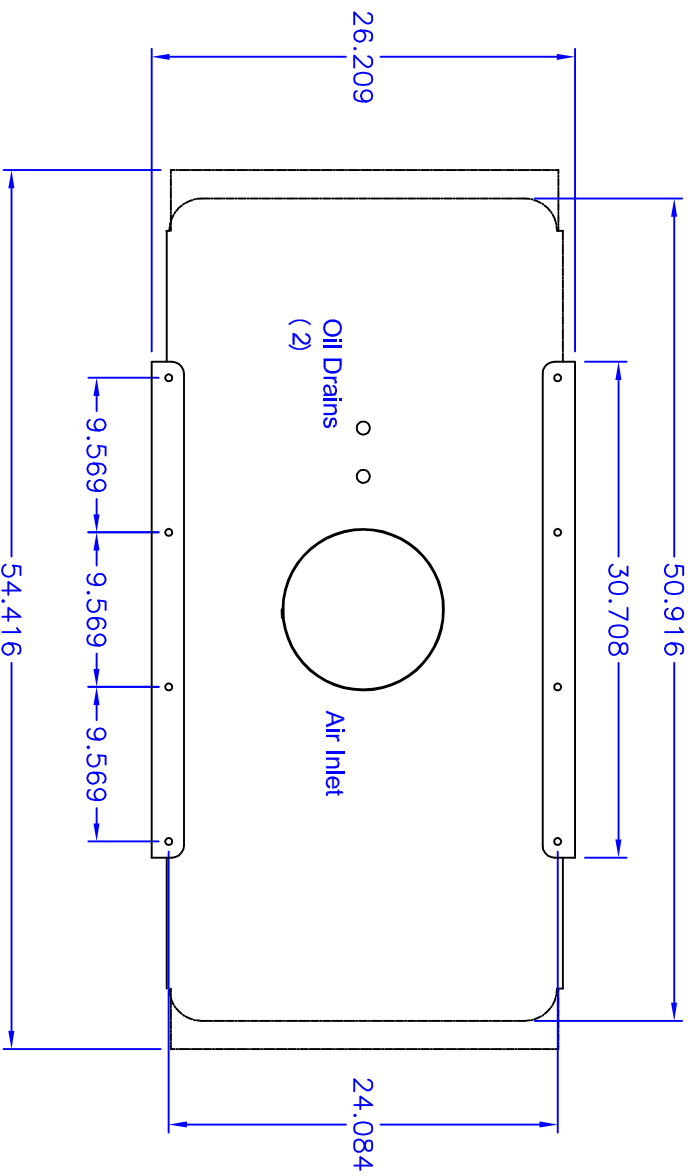

<b>AEROEX Technologies Inc.</b> 80 Ellis Drive Barrie, Ontario L4N 8Z3 Tel: (705) 734-0109 Fax: (705) 734-1013			
DESCRIPTION: ROX-2000 Footprint			
DATE:	DESIGN:	SCALE:	DWG NUM:
Jan. 26/11	T.B.		B-20-0001